



BUSINESS NEW CONSTRUCTION CHECKLIST

The items checked below apply to your application for electric service

- Application for Service form (signed and returned).
- IRS Form W-9 – Request for Taxpayer Identification Number and Certification ([See Note 1 below](#))
This form must be completed if the account will be held in the name of the business.
- Copy of Identification
*If **Yes** is marked for “Are you the owner of this business” on the Application for Service, then Driver’s License, State ID Card, Passport, Military ID, or 1-551 (immigrant visa) is acceptable.*

*If **No** is marked for “Are you the owner of this business” on the Application for Service, then an Employee ID is acceptable. ([See Note 2 below](#)).*
- Membership Fee of \$25.00 (refundable) must be paid (new members only).
- Application fee of \$80.00 (non-refundable) must be paid.
- New Service meter installation fee of \$50.00 (non-refundable) must be paid.
- Meter Base installation fee of \$100.00 (non-refundable) must be paid.
If installing a meter pack—one (1) fee of \$100.00 (non-refundable) per each pack installed.
- Service Deposit (based on projected usage or business type).
In lieu of cash deposit, customer can provide a surety bond or irrevocable letter of credit.

Notes:

1. Corporations, Partnerships, and Limited Liability Companies (LLCs) must provide a federal tax ID number at the time of applying for electric service.

Sole proprietors (individuals), S Corporations, or single-member LLCs should provide their social security number if a tax ID is not available.
2. If the person applying for service is not an owner of the business, a notarized affidavit from an Officer or Owner of the company must be signed stating the person applying for electric service has the authority to do so.

Return all required documents to Carroll Electric Cooperative:

- by electronic submission to carrollecc.com/establishing-service.
- by mail to the appropriate office (if unsure, call 1-800-432-9720.)

Carroll Electric Coop.
PO Box 4000
920 Hwy 62 Spur
Berryville, AR 72616

Carroll Electric Coop.
PO Box 329
707 SE Walton Blvd
Bentonville, AR 72712

Carroll Electric Coop.
PO Box 280
5056 Hwy 412B
Huntsville, AR 72740

Carroll Electric Coop.
PO Box 389
511 E Court St
Jasper, AR 72641



CECC USE ONLY

Account Location No. _____

Member Sep. _____ Member No. _____

BUSINESS APPLICATION FOR SERVICE

Application Date	Requested Service Start Date	Service Location Physical Address (Street, City, State, Zip)	Apt. / Suite
<input type="text"/>	<input type="text"/>	<input type="text"/>	<input type="text"/>

Company Legal Name	D.B.A.
<input type="text"/>	<input type="text"/>

Federal Tax ID	Company Phone Number	Additional Phone Number	<u>Type of Business</u> <input type="checkbox"/> Sole Proprietorship <input type="checkbox"/> LLC <input type="checkbox"/> Partnership <input type="checkbox"/> Corporation
<input type="text"/>	<input type="text"/>	<input type="text"/>	

Primary Contact	Title	Contact Phone Number	Are you the owner of this business? <input type="checkbox"/> Yes <input type="checkbox"/> No
<input type="text"/>	<input type="text"/>	<input type="text"/>	

Billing address	Email address
<input type="text"/>	<input type="text"/>

Has there ever been electric service at this location?
 Yes No (If No, complete New Construction section on page 2.)

Does this property have multiple meters?
 Yes No

If there is a **SECURITY LIGHT** at this location, would you like to keep it?
 Yes No

eSERVICES

Please enroll me in eBILLING
 Must establish myAccount ID and password to view bills.
 See myaccount.carrollecc.com for details.

eBilling email address

Please enroll me in eDRAFT

I authorize Carroll Electric to electronically debit my account monthly, for the amount stated on my bill(s) and if necessary, electronically credit my account to correct erroneous debits. I understand this authorization remains in full force and effect until I notify Carroll Electric in writing, at least five days before the due date. Cancellation instructions are available at carrollecc.com or by calling 1-800-432-9720.

<input type="checkbox"/> Checking	Name(s) on Bank Account	Bank Name	Bank City, State
<input type="checkbox"/> Savings	<input type="text"/>	<input type="text"/>	<input type="text"/>
	Bank Routing Number (max 9 numbers)	Bank Account Number (max 15 numbers)	
	<input type="text"/>	<input type="text"/>	

Use the information above to electronically debit my existing accounts (existing members only.)

COMPLETE THIS SECTION ONLY IF APPLYING FOR SERVICE AT A NEW CONSTRUCTION SITE

Property Description (Lot, Block, Phase, Subdivision, etc.)

Do you need single-phase or three-phase power?

(If three-phase, additional costs apply.)

What secondary voltage is needed at this site?

Will this structure have provisions for the following? ***(If No, additional costs apply for an unqualified load.)***

Sanitation System

Sanitary Sewer

Septic

No

Pressurized Water System

City

Well

No

Permanent Foundation

Yes

No

The Applicant, whose signature appears below, applies to the CARROLL ELECTRIC COOPERATIVE CORPORATION of Berryville, Arkansas, (hereinafter called the "Cooperative") for membership and/or electric service to be supplied at the location herein described and, upon request, at any other location within the area served by this Cooperative. This agreement shall supersede and replace any previous agreement and shall apply to each location the Cooperative furnishes electric service to the applicant.

The Applicant agrees to be bound by and to comply with all Rules of the Arkansas Public Service Commission (APSC), other applicable laws and regulations, as well as the Cooperative's approved tariffs, Articles of Incorporation, Bylaws, consumer classifications, rates, charges, and service rules and regulations and all other applicable terms and conditions set by the Cooperative, both as the same now exists or may hereafter be adopted, repealed, amended, or supplemented; to pay all fees, deposits, and charges in accordance with the rates, rules, and regulations as now exist or as may hereafter be adopted; and authorizes the Cooperative to verify information provided, including the use of any credit reporting agency to verify identity.

The Cooperative shall operate on a not-for-profit basis as defined by law. As such, all patronage capital, if any, shall be held by the Cooperative in accordance with Ark. Code Ann. §23-18-327 until such time as determined by the Cooperative. In the event the Cooperative disburses patronage capital, it shall remain the Applicant's responsibility to keep the Cooperative informed of Applicant's mailing address.

In the event the Applicant's account becomes delinquent, the Cooperative shall follow the rules and tariffs approved by APSC and thereafter, the Applicant agrees to surrender the membership fee, deposit, and future patronage capital to extinguish such indebtedness plus any accumulated late charges and interest. Further, the Applicant agrees to pay all cost of collection including attorney's fees, collection fees, and any other related fees and costs.

The Applicant will cause and keep his premises to be wired in accordance with wiring specifications of the appropriate governing jurisdiction and the Cooperative assumes no responsibility for loss or damage due to defective wiring and/or equipment located on the Applicant's side of the meter installation or other agreed to point of delivery.

The applicant understands that the Cooperative shall use reasonable diligence to provide a constant and uninterrupted supply of electric power and energy hereunder. If the supply of electric power and energy shall fail or be interrupted, or become defective through acts of God, governmental authority, action of the elements, public enemy, epidemic/pandemic, cyber-attack, accident, strikes, labor troubles, required maintenance work, inability to serve right-of-way, equipment failure, or any cause beyond the reasonable control of the Cooperative, the Cooperative shall not be liable therefore or for damages caused thereby. Electric service shall be supplied within the voltage range prescribed by Arkansas Public Service Commission's Special Rules - Electric. The Cooperative's standard service voltage will be 120/240 volts, AC, unless otherwise stated in accordance with the approved schedules, rules, regulations, or by mutual agreement. However, in all cases, the voltage supplied to the Applicant may vary by ± 5 percent measured at the meter. Voltage variations

in excess of those specified shall not be considered a violation if variations are caused by:

- (1) The operation of power equipment on a customer's premises;
- (2) The action of the elements; or,

- (3) Infrequent and unavoidable fluctuations of short duration in station operation.

The Applicant hereby recognizes the need for the Cooperative to maintain its facilities along all easements. All easements presently installed on the Applicants property, whether recorded, written, or prescriptive, are approved and granted in favor of the Cooperative.

The Applicant agrees SECURITY DEPOSITS are subject to the rules of the APSC and are subject to the following conditions:

- (1) Residential or personal deposits shall be waived or refunded based on the Applicant's timely payment history defined by the APSC and evidenced by a certification letter from a previous utility, a third-party personal guarantee from another qualifying individual, or other personal credit measurements determined by the Cooperative.

- (2) Commercial deposits, surety bonds, or irrevocable letters of credit shall be provided by the Applicant to the Cooperative and shall remain in effect for the duration of service. Should a commercial account not have a corporate taxpayer identification number issued by the Internal Revenue Service, the Cooperative shall also require a personal guarantee from the Applicant's principal business owner(s).

I understand that information on this application may be used for the purpose of a credit check and depending on the results of that credit check, I may be required to pay a deposit in full prior to electric service being connected. I hereby authorize the Cooperative along with the Cooperative's affiliates and/or service providers to obtain a credit report from any reputable credit reporting agency.

Maintaining a valid phone number will help both members and the Cooperative in reporting and restoring outages. Further, it may be necessary at times to contact members by phone electronically or otherwise regarding your account. In keeping with the provisions of the Telephone Consumer Protection Act (TCPA), 47 U.S.C. § 227, the Cooperative requires your express written consent prior to contacting you by telephone, facsimile, or text message for any non-emergency purpose using any automated telephone dialing system (ATDS) or artificial or prerecorded voice (each, an "Automated Method"). Your rights under the TCPA can be found at www.carrollecc.com/tcpa-rights or upon request. Should you choose to withhold or subsequently revoke your consent pursuant to the TCPA, or otherwise refuse to provide a valid phone number, it is with the understanding that we might not be able to reach you regarding important information about your electric service. By signing where indicated below, I authorize the Cooperative, along with the Cooperative's affiliates and/or service providers, to contact me using email and/or any Automated Method of the Cooperative's choosing, at the phone number and/or email address provided by me.

I HEREBY APPLY TO THE CARROLL ELECTRIC COOPERATIVE CORPORATION FOR MEMBERSHIP AND/OR ELECTRIC SERVICE IN ACCORDANCE WITH THE TERMS AND CONDITIONS APPEARING ABOVE.

Applicant Signature: _____

Date: _____

Co-Applicant Signature: _____

Date: _____



Establishing Service for New Construction

200 Amp Meter Base: 400 Amp Base Available

Startup Fees*:



Fees		200 Amp Meter Base	Each Add'l Meter Base - Same Location/Subd
Standard Fees	Membership Fee	\$ 25.00	\$ -
	Service Deposit**	To Be Determined	To Be Determined
Hook Up Fees	New Service Application Fee	\$ 80.00	\$ 55.00
	New Service Meter Installation/Connect Fee	\$ 50.00	\$ 50.00
	New Service Meter Base Hook Up/Wiring Fee	\$ 100.00	\$ 100.00
Meter Base	200-Amp Meter Base Package	\$ 267.23	\$ 267.23

*Note - Additional construction costs may apply if meter is set for a non-qualified load (e.g. shop building, boat dock, gate, other structures not deemed permanent).

**Service Deposit is based on projected usage or business type. In lieu of cash deposit, customer can provide a surety bond or irrevocable letter of credit.

200 Amp Main Breaker Included
As well as a 20 Amp Sub Breaker

GFCI for **Construction Power**

**Also, permanent yard outlet

Slip Joint provided for your
Permanent Power connection

For this meter base CECC provides
STANDARD TURNKEY INSTALLATION*

**** Installed in accordance with CECC Line Extension Policy on file with the Arkansas Public Service Commission which states the normal location of meter is the lot line***

Project Information Form

To be completed by CECC personnel. For informational purposes only.

- Deposits and Fees
 - See **Application for Residential New Construction Checklist** for all applicable fees
- Structure Information:
 - If known, what is the anticipated electric load? _____
 - What is the total square footage? _____
 - Electric only Propane/Natural Gas Renewable (Solar/Wind)
- Will construction consist of underground or overhead (if known)?
 - Underground Overhead
 - *Member is aware of additional construction costs for UG and/or over-distance line extension, if applicable.*
- Are there any existing facilities to be relocated?
 - Yes No
 - *Member is aware of additional costs for relocating existing facilities*
- What is the type of service:
 - Qualified Non-Qualified
 - If Qualified, have requirements been met?
 - Foundation Pressurized Water Approved Sewage disposal Installed
- Contribution-In-Aid Cost of \$_____ has been paid?
 - Yes No N/A
- Temporary if Non-Qualified, has Temporary cost of \$_____ been paid?
 - Yes No N/A
- Temporary agreement signed?
 - Yes No N/A
- Easement, this includes a continuation/exit from proposed property as well as all other properties involved. The total number of easements required is_____.
 - Yes No N/A
 - Rural (60 feet) Urban (30 feet) Underground (15 feet)

- Future construction plans for additional buildings (Example: Barn or Shop):
 - Yes No N/A
- Location of meter:
 - Pedestal Building/House (*Results in relocation cost*)
- Permits and inspections: obtained/performed
 - Yes No N/A
- Ditches properly excavated and backfilled and inspection done by a CECC Representative?
 - Yes No N/A
- Conduit termination points fit within the Cable Template (*underground transformers*)?
 - Yes No N/A
- Riser properly oriented on pole with appropriately sized slip joints and standoffs?
 - Yes No N/A
- Installation instructions.
 - The final location for the point of delivery will be at the discretion of the Cooperative.
 - **Prior to construction** contact your Field Service Representative for all applicable CECC specifications and drawings.

See the enclosed Local Contact Information page for permits and/or waivers (where applicable). Other permits or certifications may be required. Please consult with your Field Service Representative for all requirements.

- Barry County Health Department Permit or Waiver
- Benton County 911 Address “Certification of Address”
- Berryville Building Permit
- Carroll County 911 Address “Certification of Address”
- Stone County Building Permit or Waiver

Local Contact Information

Inspection/Permits:

It is the member/consumer’s responsibility to acquire any and all applicable state and local permits and/or their associated inspections. CECC will not supply power to the point of delivery without such notification from the local governing authorities. A list of authorities, their contact information, and jurisdiction has been provided for your convenience.

Arkansas One-Call	811
Missouri One-Call	811
Barry County Health Dept. or waiver	417-847-2114
Benton County 911 Address	479-271-1085
Benton County	479-271-1003
Carroll County 911 Address	870-423-6400 OR
	870-423-2388
Stone County	417-357-8402
City of Bella Vista	479-855-8080
City of Bentonville	479-271-3125
City of Berryville	870-423-2335
City of Bethel Heights	479-255-1659
City of Cave Springs	479-248-1040
City of Centerton	479-795-2750
City of Highfill	479-736-5711
City of Little Flock	479-636-2081
City of Lost Bridge Village	479-359-3204
City of Lowell	479-770-2185
City of Pea Ridge	479-451-1424
City of Rogers	479-621-1100
City of Siloam Springs	479-524-3777
City of Springdale	479-750-8154

Standard Meter Installation (1)

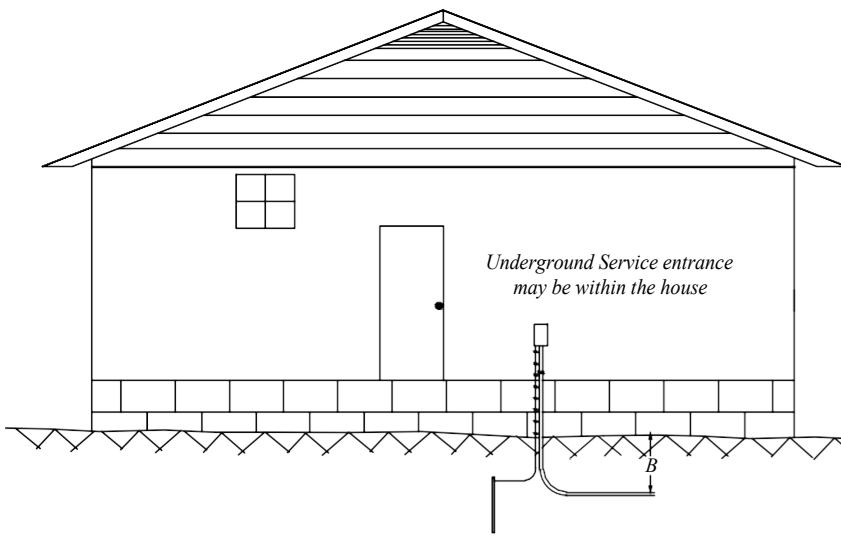

Standard Meter Installation (2)

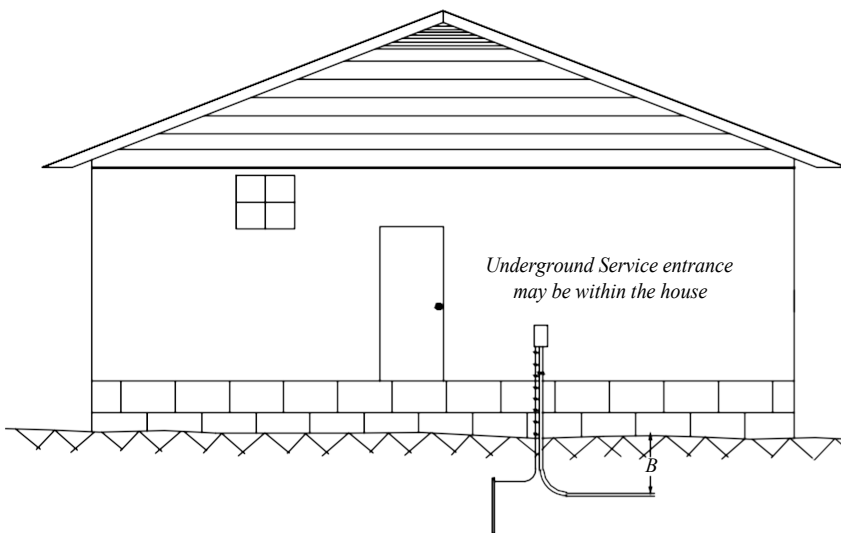

Meter Installation on Pole will NOT be allowed.

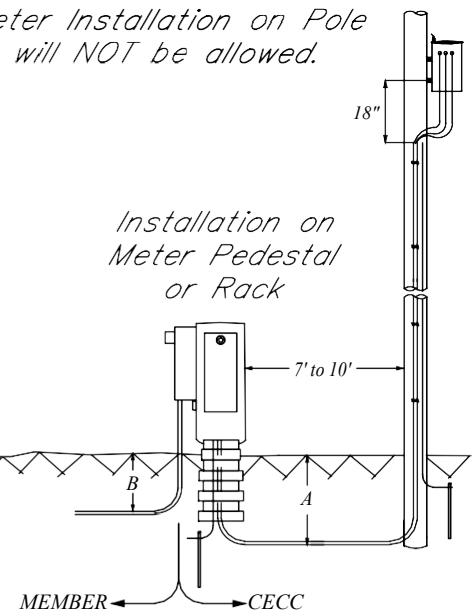

Installation on Meter Pedestal/Transformer Vaults

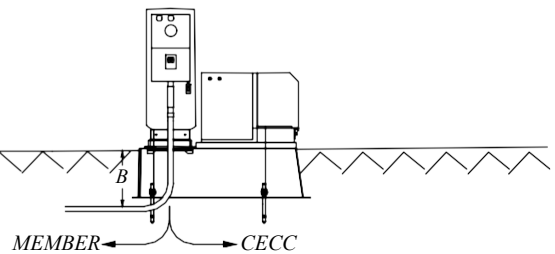

CECC Requirements

All installations per listed and NEC requirements
(local authorities may have additional requirements)

Dimension Requirements

Notes - General

- CECC will provide, install and transfer ownership of the following at minimal cost:
 - 200 meter base with breaker or 400 amp meter base with (2) 200 Amp breakers
 - 20 Amp sub breaker
 - GFCI outlet with in use all weather cover
 - (1) 2" slip joint for 200A or (2) 2" slip joint for 400A
 - Mounting hardware
- All underground conduit on utility side not installed by CECC must be Schedule 40 gray electrical PVC conduit with pull string installed minimum 1/4" pull rope or 1200# tape (or equivalent) and shall be inspected by CECC before closing trench (24 hr. notice required).
- All member conduit shall comply with current NEC.

A	36"	Minimum depth below finished grade for (bottom of ditch) CECC owned facilities.
B	18"	Minimum depth below finished grade for Member owned facilities.

Notes - CECC installation for a qualified load:

- CECC will install and provide the service wire to the point of delivery at the load side meter lugs for UG service.

Notes - CECC installation for a non-qualified load:

- All materials shall be furnished and installed at member expense including equipment, labor and associated inspections needed to accommodate the meter.

Notes - Installation on Pole:

- Meter bases shall not be installed on CECC poles.

IMPORTANT

Before installing any facilities contact:
CECC Field Service Representative
1-800-432-9720



METER BASE
INSTALLATION GUIDE

Issue: 2019
Revision: A

Page 1 of 2
STANDARD

Q2.1G, UQ2.1G

Meter Base Package Blanket Release

I, a representative of the undersigned company, hereby acknowledge I will receive a meter base package(s), from time to time, for homes which my company constructs. I accept full ownership of the following described materials from *Carroll Electric Cooperative Corporation* (the "Cooperative") upon the following terms and conditions:

- 1) A service order and charge will be created for each account I wish to purchase a meter base package. I understand payment of each meter base package constitutes my acceptance of this release for each account.
- 2) Upon installation by the Cooperative, I assume full responsibility and control of all material(s) obtained hereunder. Any costs for repair, replacement, or removal of the material(s) shall be at my expense. I understand that a licensed electrician should be the only party who repairs, replaces, or removes the materials. If the materials are installed in an area where an official inspection is required by any government agency, or any county, city, or other controlling entity, I agree that I am completely responsible for having the materials and/or installation inspected by an appropriate expert. The Cooperative will work with all local inspection offices to ensure a proper installation.
- 3) I agree to indemnify and save and hold the Cooperative harmless from any liability from any cause whatsoever that might be claimed by me, any subsequent owner, or any person or entity, claiming damages by virtue of or in any manner arising out of a defect in the material(s), the use or condition of the material(s), or any other function or circumstances relating to the material(s). In the event any legal action is brought against the Cooperative by any party for any reason regarding a defect in the material(s), the use or condition of the material(s), or any other function or circumstances relating to the material(s), the undersigned agrees to reimburse the Cooperative for any and all costs, charges, expenses, judgments, or otherwise, together with its attorney's fees and costs, to investigate and/or defend such claims.
- 4) I agree that the Cooperative shall not be held liable by me or any other party for any losses, damages, penalties, or expenses for any delay in delivery, including any delay at any point in the supply chain, of the materials referenced herein. If for any reason, the quantities of any materials available to the Cooperative are less than the Cooperative's total needs, the Cooperative may allocate its available supply of products among its existing or prospective purchasers and/or itself, for any use whatsoever, in such manner the Cooperative deems proper in the Cooperative's sole discretion, without thereby incurring liability on account of the method of allocation or its implementation. In no event shall the Cooperative be liable for any incidental, consequential, indirect, statutory, special, exemplary or punitive damages, including, but not limited to, lost profits, loss of use, loss of time, shutdown or slowdown costs, inconvenience, lost business opportunities, damage to goodwill or reputation, or other economic loss, regardless of whether such liability is based on breach of contract, tort, strict liability or otherwise, and even if advised of the possibility of such damages or such damages could have been reasonably foreseen. The liability of the Cooperative, and my sole and exclusive remedy for damages for any claim of any kind whatsoever under this agreement, regardless of legal theory, shall not be greater than the actual purchase price of those materials with respect to which such claim is made. I further agree that it is my sole obligation and responsibility to make inquiries as to the availability of said materials well in advance of my need for those materials and that the Cooperative is under no obligation, whatsoever, to alert me that it does not, or will not, have the materials requested herein at such time as they are needed, nor does the Cooperative have any duty to alert me to any delays it may encounter or has encountered in obtaining the materials.

Company Name

Representative's Printed Name

Account Number, if known

Representative's Signature

Date

ACKNOWLEDGED:
Carroll Electric Cooperative Corporation

By: _____